

Objective 12

Assignment Sheet 1—Identify Welding Processes

Name _____ Overall Rating _____

Date _____

Evaluation Criteria	Rating
• Number of correct process identifications	_____

Basic Skills



Directions

Examine the illustrations that follow. Insert the number of the process name beside the appropriate illustration.

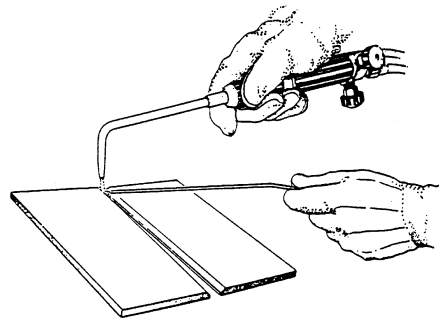

a. _____

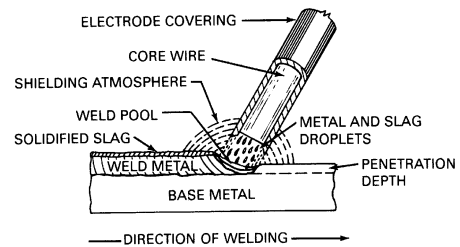

b. _____

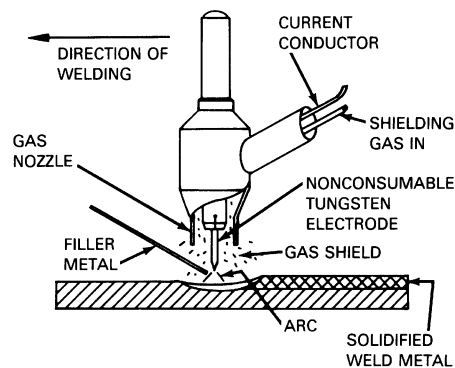

c. _____

1. GMAW
2. SMAW
3. OFW
4. GTAW

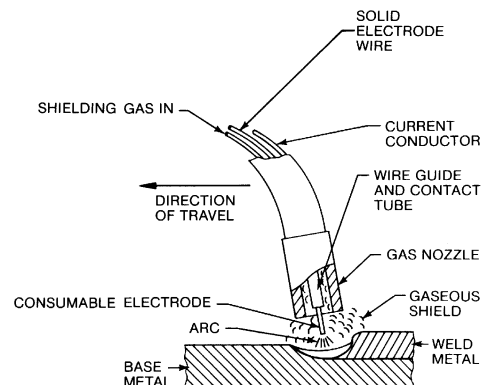

d. _____

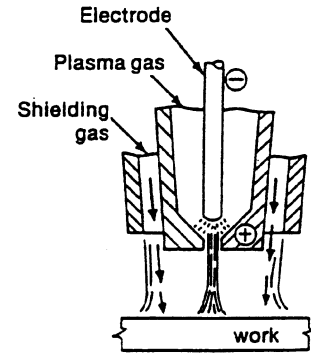
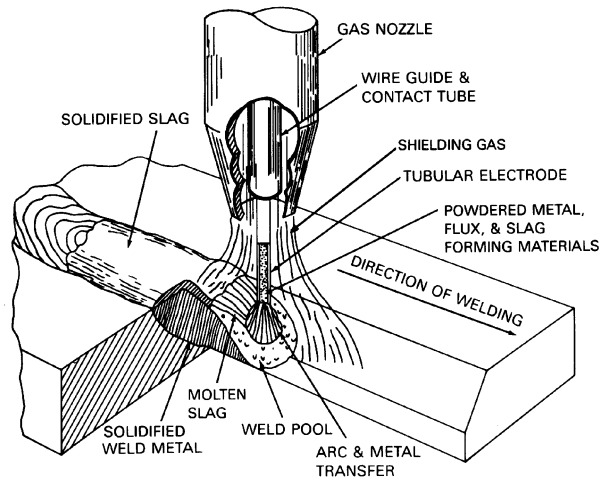

e. _____

f. _____

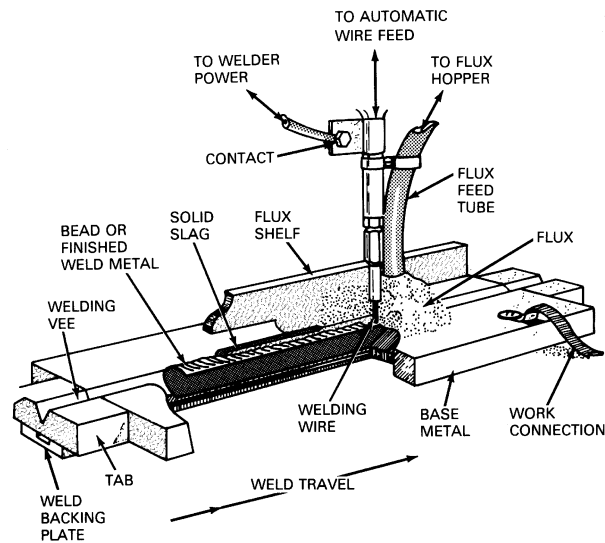

g. _____

- 5. SAW
- 6. PAW
- 7. FCAW

